

F R 锁体开槽加工图

■标准门厚 28~36 mm

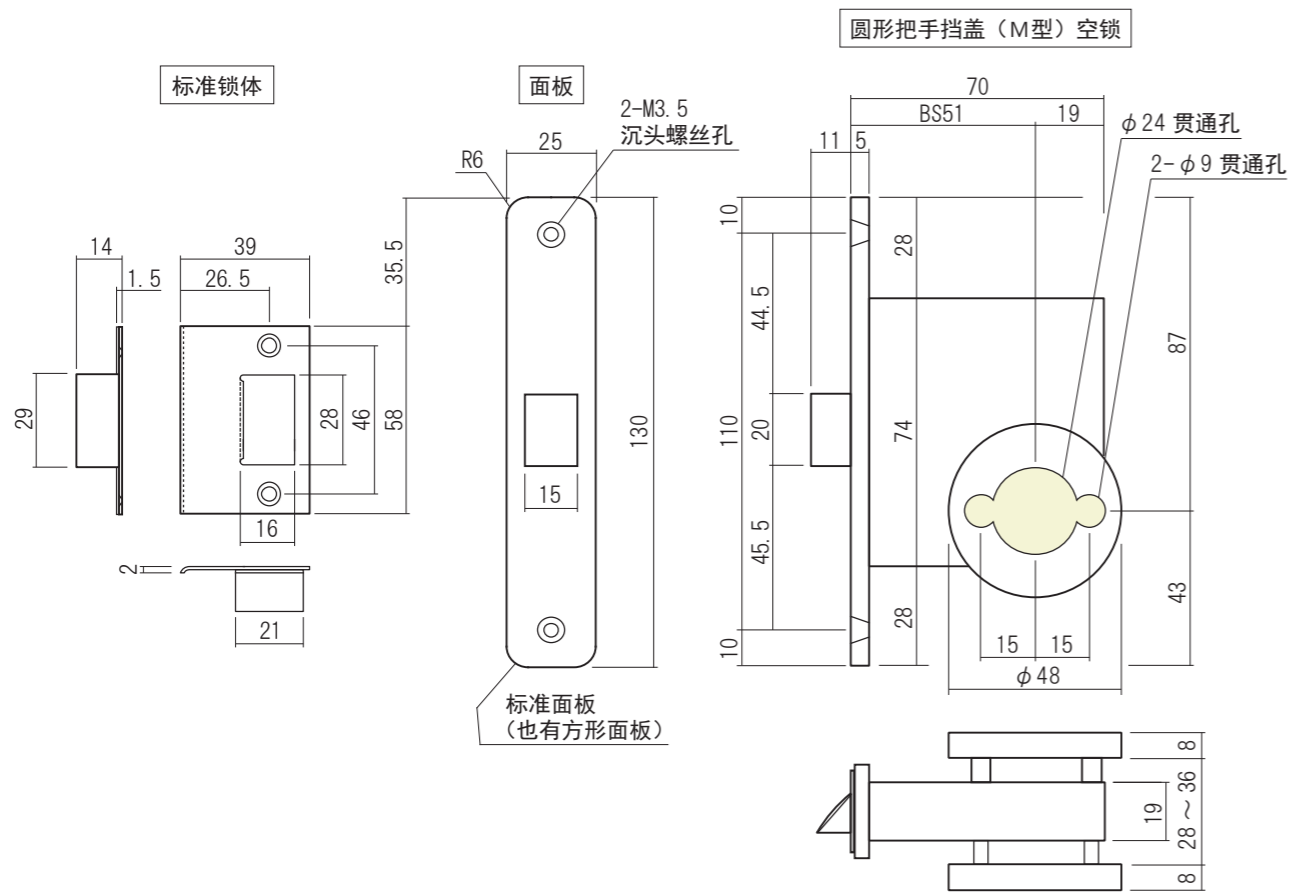

F T 锁体开槽加工图

■标准门厚 28~36 mm

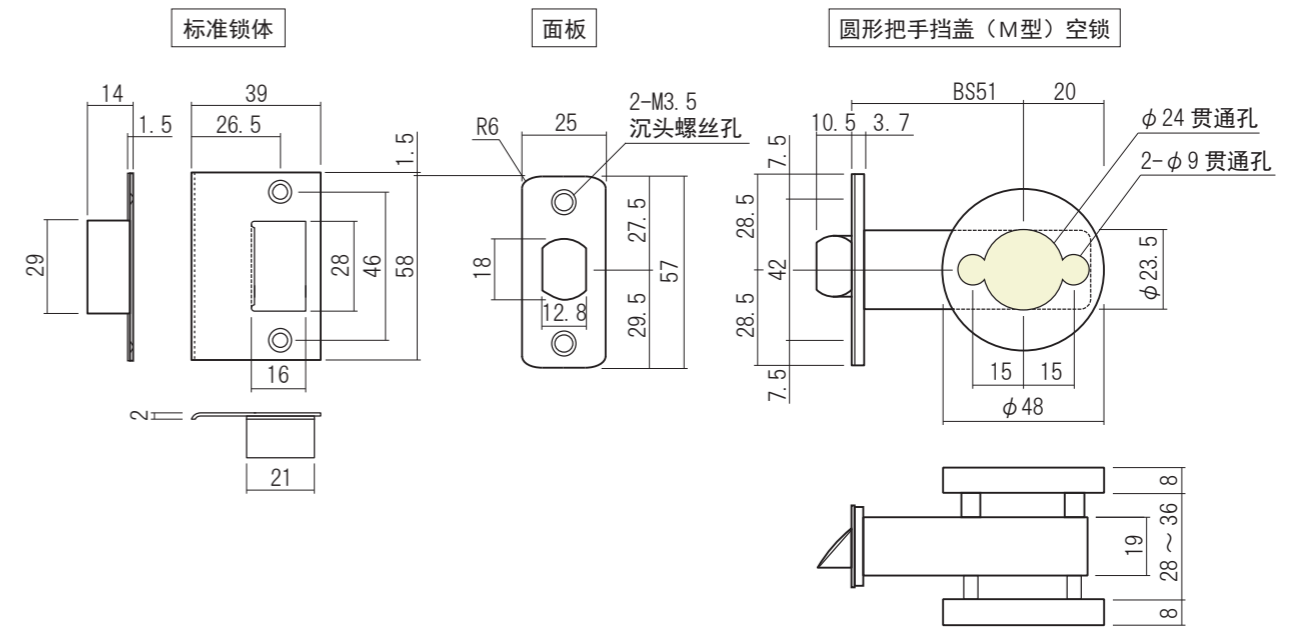

组装图

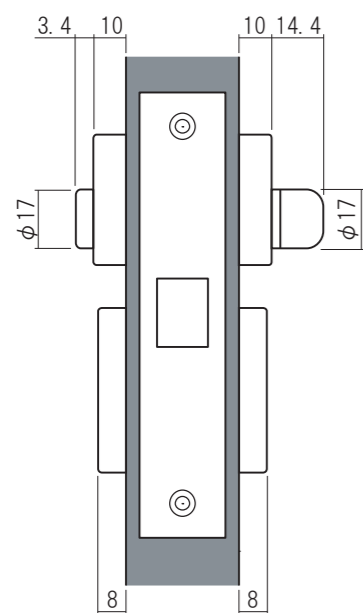

通道锁·带表示通道锁

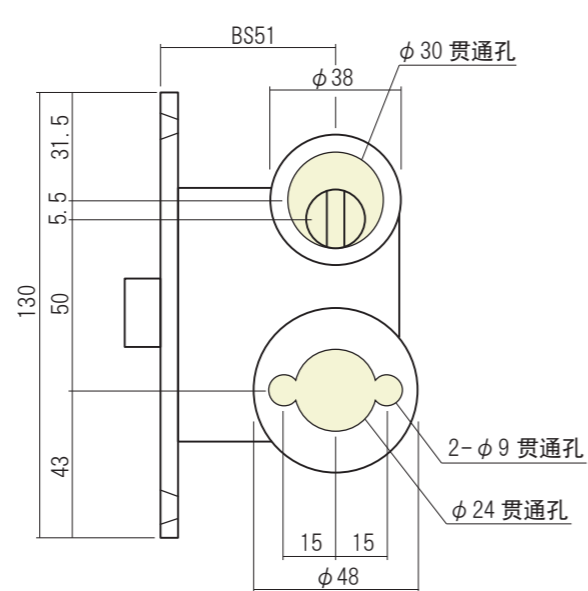

...表示需要开槽的位置

组装图

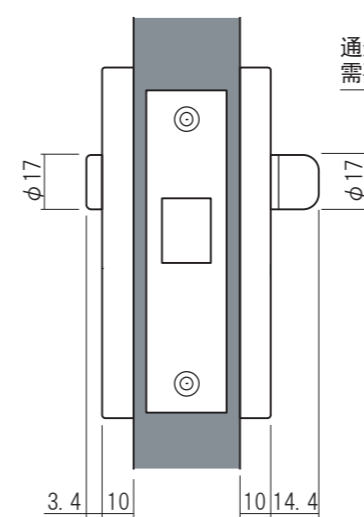

椭圆形把手挡盖 (C型)

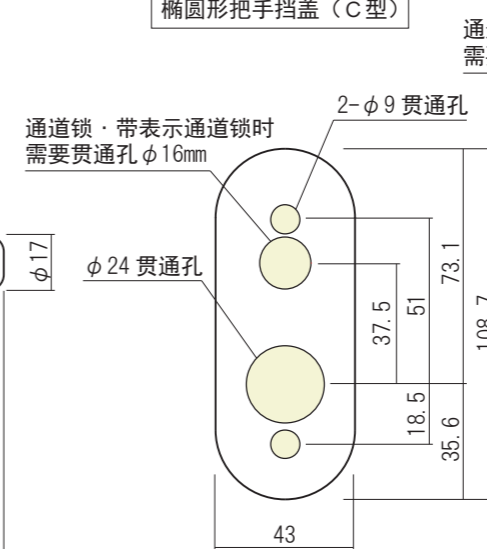

方形把手挡盖 (L型)

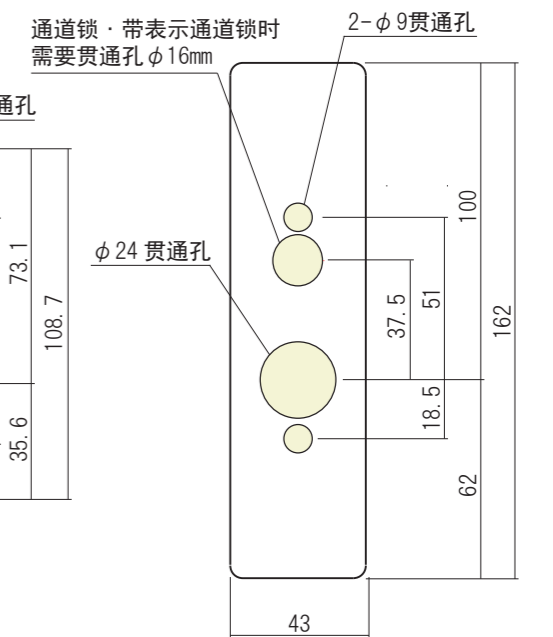

...表示需要开槽的位置